



# **MAX** *Impact Power*

## **Operators Instruction & Parts Manual**

### **MAX K95S**



Version 2023

*Model: MAX K95S*

*Registration number:.....*

*Purchase date:.....*



DURING THE NO-DIG POLAND  
"TRENCHLESS TECHNOLOGIES" CONFERENCE,  
THE MAX K95S MOLE WAS AWARDED  
THE 2012 EXPERT STATUETTE

<b>Table of contents:</b>	<b>Page</b>
<b>1 TECHNICAL INFORMATION .....</b>	<b>4</b>
1.1 MAX K95S BASIC SET .....	4
1.2 THE BASIC SET INCLUDES .....	5
1.3 TECHNICAL DATA OF AIR COMPRESSOR.....	5
1.4 ACCESSORIES.....	6
<b>2 SAFETY INSTRUCTIONS .....</b>	<b>8</b>
2.1 WARNING SIGNS: .....	8
2.2 PROHIBITORY SIGNS:.....	8
2.3 MANDATORY SIGNS:.....	9
<b>3 USE OF MAX K95S.....</b>	<b>9</b>
<b>4 OPERATION PRINCIPLE .....</b>	<b>9</b>
<b>5 CONSTRUCTION.....</b>	<b>10</b>
5.1 MAX K95S .....	10
5.2 AIR PRESSURE HOSE .....	11
5.3 MAX-LUBRICATOR WITH REVERSING MECHANISM .....	12
<b>6 TRANSPORTATION.....</b>	<b>13</b>
<b>7 PREPARATIONS BEFORE USE.....</b>	<b>14</b>
7.1 GENERAL INSTRUCTIONS.....	14
7.2 STARTING PIT.....	14
7.3 TARGET PIT .....	15
<b>8 OPERATION .....</b>	<b>15</b>
8.1 SAFETY INFORMATION .....	15
8.2 CONVERT THE MAX K95S.....	15
8.3 CONNECTING THE AIR HOSE .....	16
8.4 FUNCTIONS OF THE LUBRICATOR .....	17
8.5 ALIGNMENT OF THE MAX K95S .....	18
8.6 SOLO-BORING .....	19
8.7 REVERSING MAX K95S .....	20
8.8 MANUAL PULLING OF PLASTIC PIPES .....	21
8.9 DIRECT PULLING PE-, PVC- PIPES OF DIAMETER 75 MM .....	21
8.10 DIRECT INSTALLING PE-, PVC- PIPES OF DIAMETER 90 MM.....	22
8.11 STEEL PIPES RAMMING .....	23
8.12 CLEANING OF STEEL PIPES AFTER RAMMING .....	24
8.13 EXPANDING THE BOREHOLE .....	26
8.14 AFTER CARE .....	27
<b>9 MAINTENANCE .....</b>	<b>27</b>
9.1 ROUTINE MAINTENANCE .....	27
9.2 IN CASE MAX HAS NOT BEEN IN USE FOR A WHILE.....	28
9.3 TECHNICAL INSPECTIONS .....	29
<b>10 TROUBLESHOOTING.....</b>	<b>30</b>
<b>11. SPARE PARTS .....</b>	<b>32</b>
11.1 MAX K95S – MOLE SPARE PARTS LIST .....	32
11.2 PNEUMATIC AIR HOSE 20 M SPARE PARTS LIST .....	34
11.3 LUBRICATOR WITH REVERSING MECHANISM .....	36

## 1 Technical information

### 1.1 MAX K95S basic set

#### 1.1.1 MAX K95S

Parameter	Unit	Value
Diameter	[mm]	95
Length	[mm]	1641
Weight	[kg]	56
Air consumption, min (recommended)	[m <sup>3</sup> /min]	1,7 (2,5)
Working pressure	[bar]	7
Frequency	[Hz]	6

#### 1.1.2 Air Hose

Parameter	Unit	Value
Diameter	[mm]	25
Length	[m]	20
Weight	[kg]	25

#### 1.1.3 Lubricator with Control Panel

Parameter	Unit	Value
Length	[mm]	655
Width	[mm]	232
Height	[mm]	180
Weight (without oil)	[kg]	15,8
Tank capacity	[l]	3,1
Working pressure	[bar]	7



## 1.2 The Basic Set includes

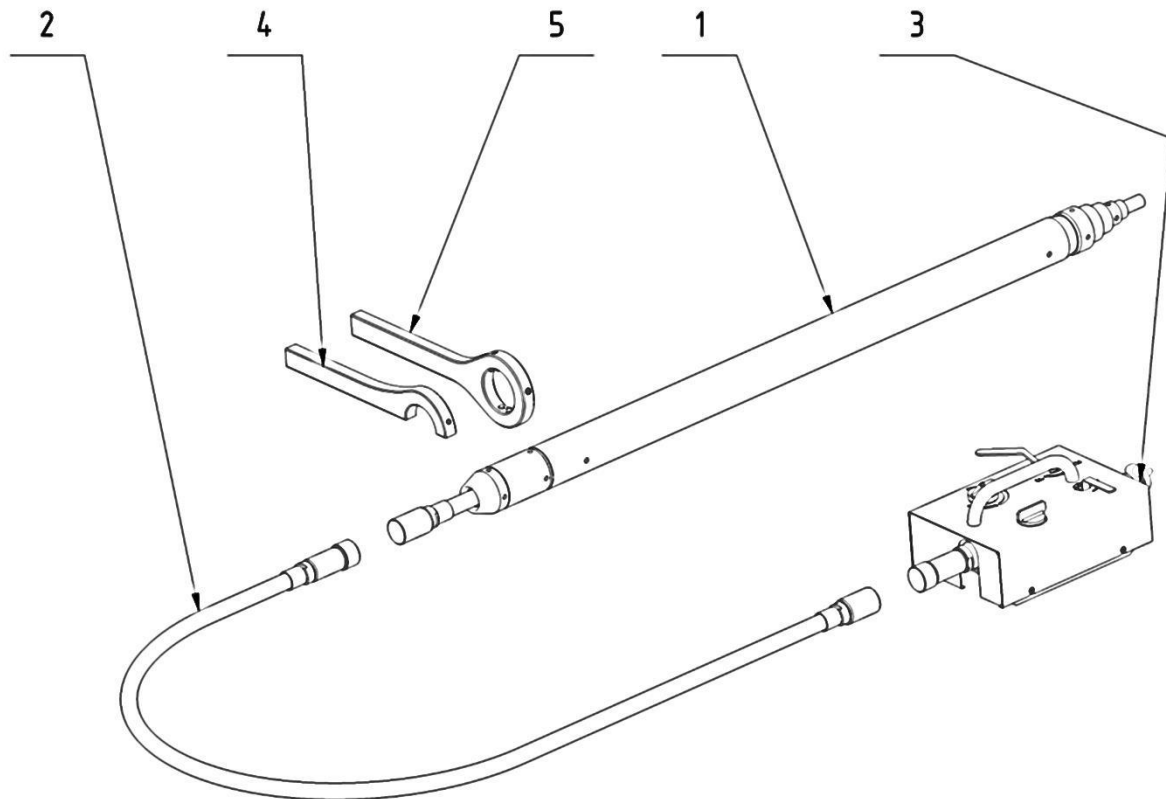

Figure 1.2.1

No.	Description	Pcs
1.	Ground Rocket MAX K95S	1
2.	Air Hose 20 m	1
3.	Lubricator / Control Panel	1
4.	Hook spanner wrench	1
5.	Ring spanner wrench	1

## 1.3 Technical data of air compressor.

Parameter	Unit	Value
Capacity	[m <sup>3</sup> /min]	min 2,4
Working pressure	[bar]	7
The opening pressure of the safety valve	[bar]	max 10
Valve capacity	[m <sup>3</sup> /min]	min 2,3
Connection type		GEKA in acc. DIN 3228

#### 1.4 Accessories

With MAX K95S the following accessories can be used:

a) For the alignment of MAX:

- Optical level set



b) For installing plastic tubes, directly behind the machine:

- Tool for pulling PE/PVC pipes diameter  $\varnothing 75$  mm (threaded)



- Tool for pulling PE/PVC pipes diameter  $\varnothing 90$  mm (with rope)



- Tensioner with replaceable adapters



- Steel pulling rope  $\varnothing 8$  mm with interconnector

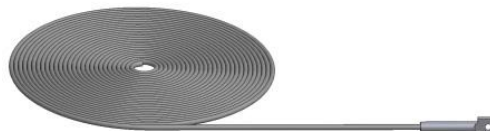

- Tool to insert plastic pipes  $\varnothing 25$ - $\varnothing 55$  mm manually



- c) For ramming steel pipes  
- cones: S090190, S180240



S090190

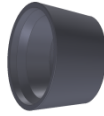

S180240

- d) To clean the pipes from sand and debris after ramming  
- Pipe plugs and locking rods for them



- Air pressure hose with valve (for the pipe plugs)



- Foam pipeline pig



- e) for increasing bore's diameter up to 125 mm:  
- expander / calibrator



- f) For lubrication we recommend to use EkoMAX. An environmental friendly product that consist of bio-degradable components. The EkoMAX lubricant is available in 5 and 20 liter canisters.



## 2 Safety Instructions

The use of the machine may represent a danger to the health and life of users or third parties. Failure to follow these instructions could result in serious personal injury or death. All tools, materials and equipment manufactured and supplied by TERMA, are designed to be used by qualified and trained personnel only. TERMA will not be held liable for any injury or damage to either people or property resulting from the misuse of TERMA equipment.

### 2.1 Warning signs:



*Danger to people, this symbol is used in conjunction with an inscription that says danger!*



*Danger of underground utilities!*



*Danger of explosion!*



*Danger of loud noise!*



*Entrapment hazard!*



*High Air pressure!*

### 2.2 Prohibitory Signs:



*General prohibition signs; this symbol is used in conjunction with a suffix that makes statements about the ban.*



*No unauthorized persons allowed!*



### 2.3 Mandatory Signs:



***Wear ear protection!***



***Wear safety glasses!***



***Do not start, operate or service MAX until you have read and understood the operator's manual. Failure to do so could result in serious injury!***



***Wear hand protection!***

### 3 Use of MAX K95S

The MAX K95S can be used to execute tunneling and with the use of appropriate accessories for pulling of PE, PVC pipes and steel pipes' ramming.

Using the MAX K95S for other purposes is not permitted. The manufacturer will not be held responsible for any damage sustained through improper use of the MAX K95S.

### 4 Operation principle

The MAX K95S is a pneumatic earth piercing tool, which is driven through the ground by compressed air. Like any pneumatic tool, MAX requires a compressor with adequate capacity for optimal operation. To ensure the longevity of the MAX, over pressure (more than 7 atm.) should be avoided at all times.

The compressed air passes through the MAX-lubricator to the air hose attached to the MAX and moves the machine forward or backward. The exhausted air leaves the MAX via its backside. The MAX lubricator is equipped with valve to enable a change of direction by simply moving the handle from position F to position R.

## 5 Construction

### 5.1 MAX K95S

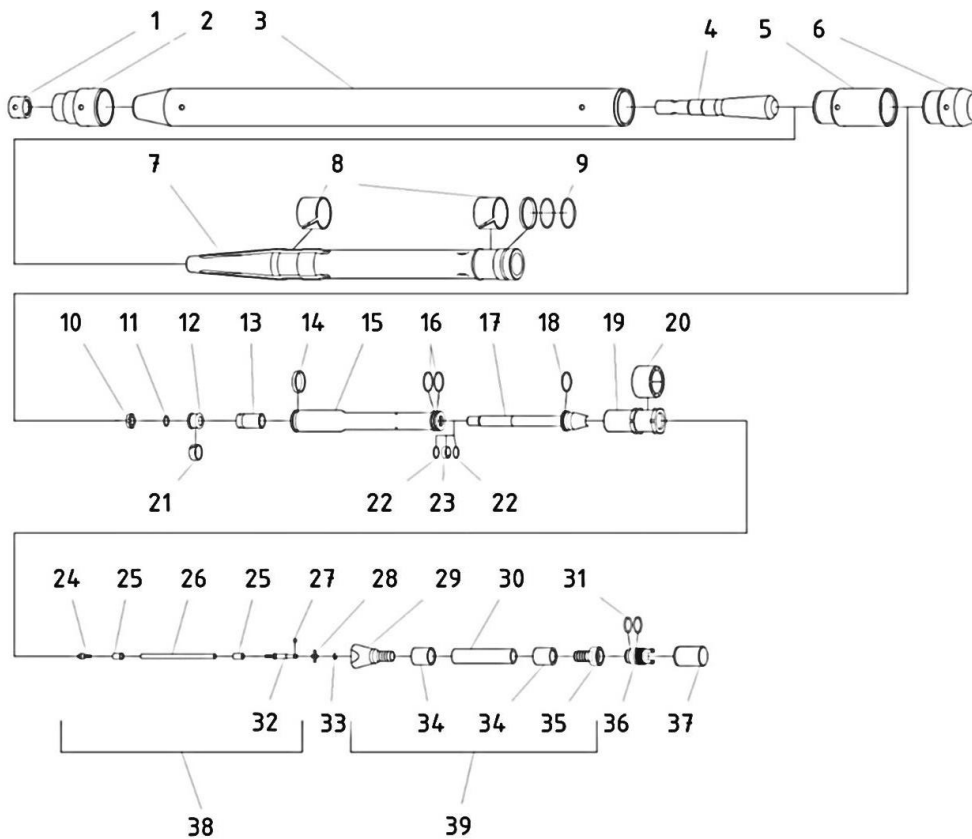

Figure 5.1.1

No.	Name	Item number	QTY
1.	Stepped head nut	PMNAK-M095-00.09	1
2.	Stepped head	PMNAS-M095-00.01-M3	1
3.	Cylinder	PMCYL-M095-00.02-M2	1
4.	Chisel	PMPRZ-M095-00.08	1
5.	Control stud housing	PMTSR-M095-00.03	1
6.	Reverse cone with pulling eyes	WAHW095	1
7.	Impact piston	PMBIJ-M095-00.05-M3	1
8.	Piston teflon sliding tapes	PMPRB-M095-00.06	2
9.1.	Piston seal (Teflon)	PMUSB-M095-00.07	1
9.2.	Piston seal (O-ring 69x3)	MTSORSI0033	2
10.	Control rod nut	PMNKSP-S095-00.10	1
11.	Seal (O-ring 22x2)	MTSORSI0011	1
12.	Inner piston	PMTLOK-S095-00.04	1
13.	Elastic damper	PMAMOR-S095-00.06	1
14.	Control piston teflon seal	PMUTS-S095-00.01-P3	1
15.	Control piston	PMTLS-S095-00.02	1
16.	Control piston seal II (2x O-ring 45x2,5)	MTSORSI0016	2
17.	Control rod	PMRUS-S095-00.05	1
18.	Control cylinder seal (O-ring 45x2,5)	MTSORSI0016	1
19.	Control cylinder	PMCYLSTR-S095-01.00	1

20.	Elastic block	PMLST-S095-00.08	1
21.	Inner piston sliding tape I	PMPT1-S095-00.03	1
22.	Control piston seal III (2x O-ring 26x2)	MTSORSI0012	2
23.	Control rod sliding tape II	PMPT2-S095-00.09	1
24.	Control hose connector	PMKWC-S095-00.11	1
25.	Control hose crimping ferrule M95	PMTULZW-W095-00.11	2
26.	Control whip hose 0,20 m	MTSWG0016	m
27.	Control hose seal (O-ring 4.3x2.4)	MTSORNB0004	1
28.	Control hose cross spacer M95	PMWWC-W095-00.08	1
29.	Outer hose barbed connector	PMKWG-S095-00.07	1
30.	Outer whip hose (0,15 m)	MTSWG0018	m
31.1.	Coupler seal (O-ring 32x4)	MTSORIU0005	1
31.2.	Coupler seal (O-ring 35x3,5)	MTSORIU0006	1
32.	Control hose barbed coupling (male)	PMLWCM-W095-00.07	1
33.	Retaining ring (E-clip) M95	MMEMNPZ0004	1
34.	Outer hose crimping ferrule M95	PMTULZW-W095-00.10	2
35.	Outer hose barbed coupling female M95	PMLWG-W095-00.04	1
36.	Outer hose quick coupler (male) M95	PMSRB-W095-00.05	1
37.	Dirt cap (female)	PMZAZ-W095-00.06	1
38.	Control whip hose, complete (Pos. 24, 25 x 2, 26 x 0.20, 32, 27)	PMWKC095K	1
39.	Outer whip hose, complete (Pos. 29, 30 x 0.15, 34 x 2, 35, shrink, work)	WAWZ095	1
...	Shrink pipe RPK 40/12 for whip hoses M65, M75, M95	TMRPK40/012	1
...	Seal kit M95 basic (Pos. 8 x 2, 9, 14, 27)	WAUM095M	1
...	Seal kit M95 complete (Pos. 8 x 2, 9, 11, 14, 16 x 2, 18, 21, 22 x 2, 23, 27, 31)	WAUK095	1

## 5.2 Air pressure hose

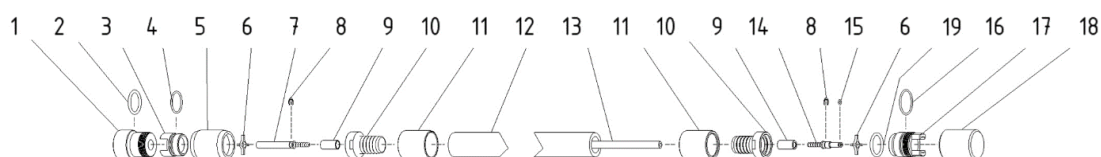

Figure 5.2.1

No.	Name	Item number	QTY
1.	Dirt plug (male)	PMZAW-W095-00.01	1
2.	Dirt plug seal (O-Ring 32x4)	MTSORIU0005	1
3.	Outer hose quick coupler (female)	PMLWZ-W095-00.03	1
4.	Coupler seal (O-Ring 29x3,5)	MTSORNB0030	1
5.	Coupler nut	PMNAW-W095-00.02	1
6.	Control hose cross spacer M95	PMWWC-W095-00.08	2
7.	Control hose barbed coupling (female)	PMLWCZ-W095-00.09	1
8.	Retaining ring (E-clip) M95	MMEMNPZ0004	2
9.	Control hose crimping ferrule M95	PMTULZW-W095-00.11	2
10.	Outer hose barbed coupling female M95	PMLWG-W095-00.04	2
11.	Outer hose crimping ferrule M95	PMTULZW-W095-00.10	2

12.	Outer hose 20 m	MTSWG0010	m
13.	Control hose 20 m	MTSWG0016	m
14.	Control hose barbed coupling (male)	PMLWCM-W095-00.07	1
15.	Control hose seal (O-Ring 4,3x2,4)	MTSORNB0004	1
16.	Coupler seal (O-ring 35x3,5)	MTSORIU0006	1
17.	Outer hose quick coupler (male) M95	PMSRB-W095-00.05	1
18.	Dirt cap (female)	PMZAZ-W095-00.06	1
19.	Coupler seal (O-ring 32x4)	MTSORIU0005	1
...	Control hose 20m, complete M95 (Pos. 7, 9 x 2, 13 x 20, 14, 15, work)	WAWWC095W	1
...	Air supply/control hose 20 m, complete M95	WAWZ09520	1

### 5.3 MAX-Lubricator with Reversing Mechanism

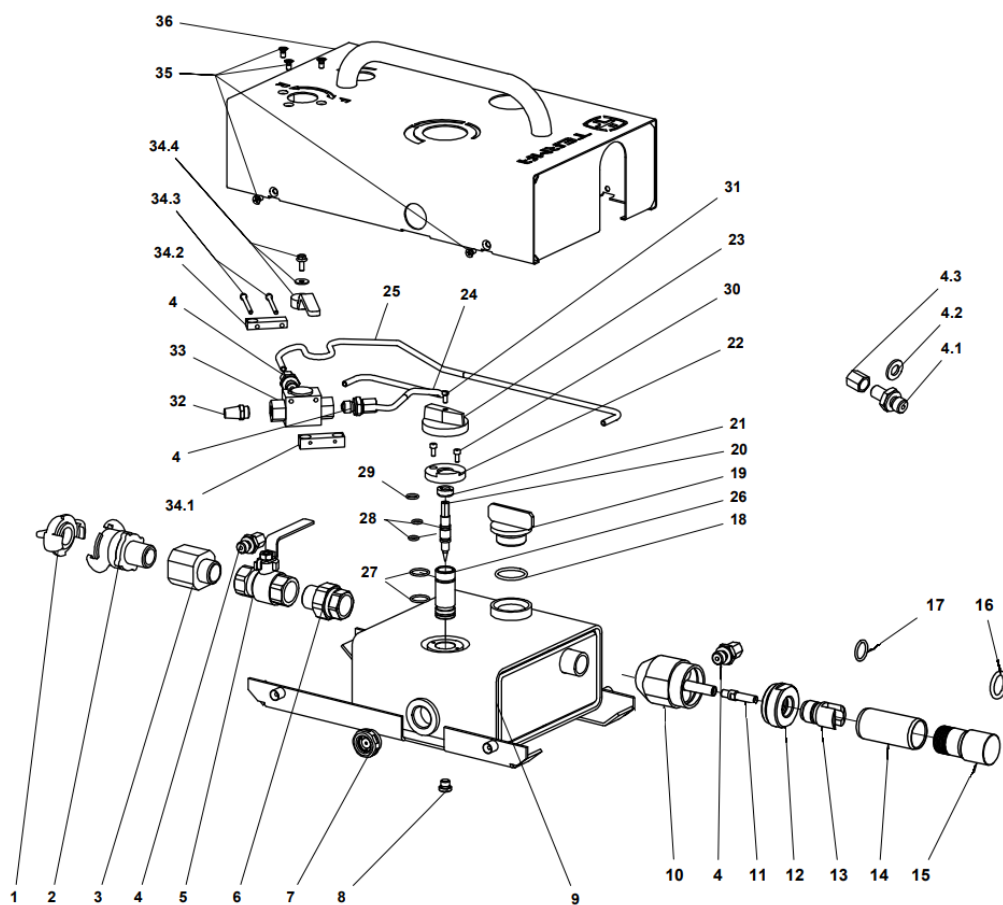

Figure 5.3.1

Nr.	Name	Item number	QTY
1	GEKA dust cap with chain 42 mm	MMEHYZS0002	1
2	GEKA GZ-Coupling 42 mm 3/4"	MMEHYZL0002	1
3	Splitter II	PMRZG2-OL130-00.01	1
4.1.	XGE 6LR fitting from 1/4" straight connector	MMEHYZL0006	4
4.2.	DPR 6L/S compression ring from 1/4" straight connector	MMEMNIN0004	4
4.3.	Nut M12x1.5 M 6L from the straight connector 1/4"	MMEMNNA0006	4

5	Ball valve 3/4"	MMEHYZA0004	1
6	Threaded plug GN 749 1/8"	MMEMNKR0002	1
7	Union fitting 3/4"	MMEHYSR0001	1
8	Oil level sight glass 3/4"	MMEMNIN0008	1
9	Tank container	PMZZM-OL130-01.00-M1	1
10	Splitter I (set)	PMRZG1-OL130-03.00-M1	1
11	Straight standpipe hose tail 55	PMKWO-OL095-00.02	1
12	Reducer M55	PMRD-OL095-00.03	1
13	Outer hose connector (female) M55	PMLWZ-W095-00.03	1
14	Air hose nut M55	PMNAW-W095-00.02	1
15	End cap M55 (male)	PMZAW-W095-00.01	1
16	O-ring 21x4 80NBR	MTSORIU0005	1
17	O-ring 17,3x2,4 NBR70	MTSORSI0013	1
18	O-ring 30,2x3 of oil cap, 70NBR	MTSORNB0032	1
19	Oil cap	PMKWO-OL130-04.00	1
20	Needle valve	PMIGL-OL130-02.00	1
21	Gland (stuffing box)	PMDŁ-OL130-02.03	1
22	Clamping plate	PMJAR-OL130-00.04-M2	1
23	Flow control knob	PMPOL-OL130-00.05-M2	1
24	Hydraulic pipe fi6x1	MMERUHY0001	0,39
25	Hydraulic pipe fi6x1	MMERUHY0001	0,57
26	Needle seat	PMGNIG-OL130-02.01	1
27	Needle seal (O-ring 18x2)	MTSORNB0011	2
28	Needle seal (O-ring 8x2)	MTSORNB0056	2
29	Gland seal (O-ring 10x2)	MTSORNB0001	1
30	Clamping plate screw M4x10 DIN 912	MMEMNSR0058	2
31	Flow control knob screw M4x10 DIN 933	MMEMNSR0059	1
32	Sintered bronze silencer 2931-1/4" Camozzi	MMEHYTL0001	1
33	Three way ball valve with holes 1/4" BSP 500 BAR	MMEHYZAOTW0005	1
34.1	Valve mounting block 1	PMKMZ-OL130-07.01	1
34.2	Valve mounting block 2	PMKMZ-OL130-07.02	1
34.3	Allen screw M4x50 ISO4762 OC 5,8	MMEMNSR0658	2
34.4	Handle for three-way ball valve 1/4" WKH and WKH3 (R12)	MMEHYZA00065	1
35	Screw M5x10 Z (WSM)	MMEMNWK0026	7
36	Oiler body	PMOOM-OL130-05.00Z	1

## 6 Transportation

Due to the heavy weight of the machine, the MAX K95S should be handled with extra care and only be transported and lifted with leads. When moving the MAX by hand, ensure that you always lift the body of the MAX.

**MAX should never be moved, carried, pulled or dragged by the hose!**  
**This is a precaution to avoid any damage to the hose, MAX and yourself!**

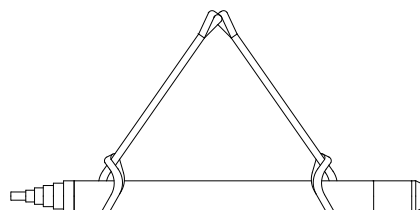



*The machine should be securely moved and lifted by straps at the front and back of the cylinder, in such a manner that sliding out is avoided*



*Make sure there are no persons under a lifted device! Persons under the load are in a danger zone for themselves and others.*

*Always check the quality and condition of the lifting straps before use!*

## 7 Preparations before use

### 7.1 General Instructions

Before starting the MAX, you need to check for the existence and exact position of buried pipe and cables by contacting the respective owners of utilities or networks. The exact location and existence of the buried cables and pipes should be determined by using trial pits or cable and pipe detection equipment.



*The area where work is carried should be marked and locked to avoid unauthorized entry to the site!*



*Should you accidentally hit an electrical cable, leave the site immediately. Ensure no-one else enters the site and contact the electrical company to turn off the electrical supply!*



*Should you accidentally hit a gas pipe, leave the site immediately, ensure no one else enters the site and contact the gas company to turn off the gas supply!*

### 7.2 Starting pit

The minimum depth specification for operation of the MAX is ten times the tool diameter. (10 x 95 mm = 950 mm). Minimum cover = 10 x Diameter of the MAX. If the minimum depth is not observed, there is a risk of surface damage from soil displacement. The length of the starting pit depends on the type of hole and the use of accessories (Solo-Boring or pipe pulling).

The starting pit needs to have enough space for the MAX accessories and pipes. The air pressure hose must be fully rolled out (avoid kinking).

The starter pit width should allow free access to the MAX, and its accessories precise alignment.



*For narrow Start and End pits (especially those with a depth of 1 meter or more) we recommend that the Start and End pit walls are supported, this is to avoid undue strain, and potentially, their collapse!*

*Always ensure that work is carried out in areas marked clearly with signage stating that work is in progress. No entry to any unauthorized persons!*

### 7.3 Target pit

The width and depth of the End pit should be able to take the MAX out of the pit without obstruction - even if the drilling direction has been adjusted.

If for any reason this is not possible, the MAX should be reversed to the Starting pit and removed from there.

## 8 Operation

### 8.1 Safety information

MAX impact mole should be used at ambient temperatures not lower than + 5 °C. Working in smaller temperatures may cause stop the machine during operation.



***Operation of MAX K95S only to be carried out by suitably trained, qualified, and certified personnel only. New operators or operators in training should only work under the constant supervision of a fully qualified person.***



***Operating crew should always wear the appropriate safety equipment: ear protection, safety shoes/boots, hard hat, safety glasses, gloves etc.***



***All items should be inspected before any work commences.***



***Faulty or damaged items should be replaced immediately by a trained, qualified and certified person only.***



***The MAX should only be operated when all parts (lubricator, hoses, accessories) have been secured, connected and checked***

***Any changes or alterations to the MAX or to the accessories will invalidate the guarantee.***

### 8.2 Convert the MAX K95S

To perform different types of work (Solo-Boring or Pipe pulling) the MAX can be upgraded with certain accessories (end cone or tool for pulling PE/PVC pipes) shown in below table:

Type of work	End nut	Tool for inserting PE/PVC threaded	Tool for inserting PE/PVC with rope
Solo-Bore	+	-	-
Direct PE/PVC pipe installing $\phi 75$ , $\phi 90$	-	+	+
Steel pipe ramming	+	+	+

+ correct use;

- incorrect use

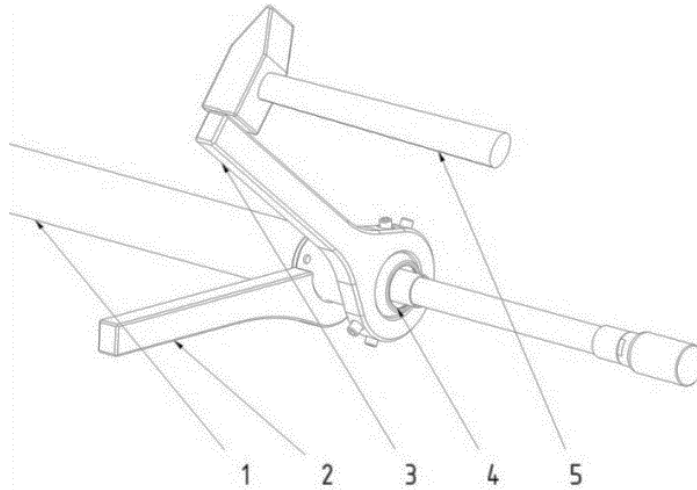

Figure 8.2.1

To replace a rear part (Figure 8.2.1) follow these proceedings:

- a) Disconnect the machine from the air compressor.
- b) Place MAX **(1)** spanner wrench **(2)** on a solid and stable surface. The spanner wrench' pins must be placed into the indentations.
- c) Mount the eye spanner **(3)** on a part which should be unscrewed **(4)**. The eye spanner wrench' pins must be placed into the indentations.
- d) Check if the spanners are properly fixed then use a large hammer **(5)** onto the eye spanner wrench **(3)** to loosen a screw.
- e) When loose, unscrew a rear part by hand.



***It is strictly forbidden to use the MAX without an End part (End cone/Tool for pulling PE/PVC pipes). The engaging of the machine without a rear part will result a sudden powerful ejection of control piston out of the cylinder.***

- f) Teflon tape residues and other dirt on the thread of the component should be cleaned with a wire brush.
- g) The threads of the part to be fitted need to be wrapped the opposite way to the screwing direction with teflon tape. We recommended LOCTITE 55, at last two or three threads.
- h) Place the taped part into the MAX, then, screw it tight with the eye spanner wrench until you have some resistance.
- i) Tighten with eye spanner wrench and a big hammer

### 8.3 Connecting the Air Hose



***Before connecting, blow air through the air hose to remove dirt or any other debris or contamination.***

To connect the air hose (Figure 8.3.1) proceed as follows:

- a) Place the compressor in a safe and stable location, taking into consideration the length of the pneumatic hose and the expected bore's length.





**Secure the compressor to avoid unexpected movements.**

b) Connect the air hose **(1)** to the compressor, ensure the hose is securely interlocked and the safety rings are tightened. Blow some compressed air through the air hose to remove dirt or other contaminations.



**Do not aim blowing air from the hose at people. The air and dirt mixture could possibly cause injury.**

c) Release the lock of GEKA-coupling by turning it anticlockwise. Remove the GEKA locking cap **(2a)** from the Lubricator **(2)** connect the compressor air hose **(1)** with appropriate GEKA hose end coupling ( $\frac{3}{4}$  " ; 42 mm).



**Please note that the GEKA coupling must be secured with a nut to prevent inadvertent decoupling.**

d) Unscrew dust cap female **(2b)** from the Lubricator and end cap male **(3a)** from the pneumatic air hose, then connect the pneumatic air hose to the Lubricator. Screw with nut firmly together until resistance is felt.

e) Unscrew the protective end cap female **(3b)** from the pneumatic air hose. Clean the air hose and inner control hose by blowing some air through them. Use pneumatic control valve to switch the flow of compressed air between hoses.

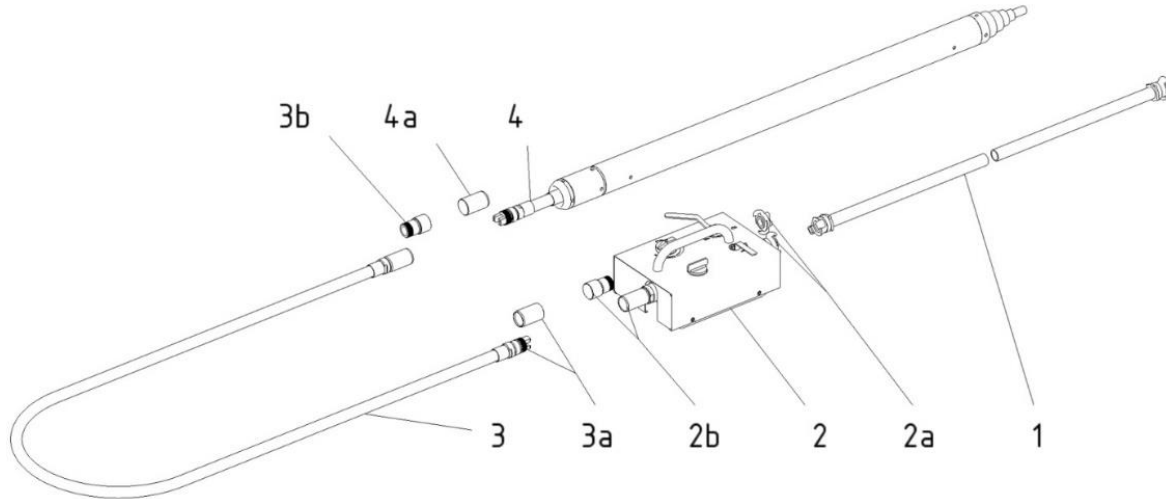

Figure 8.3.1

f) Place the MAX in the Starting Pit and remove the end cap female **(4a)** from the short hose of the MAX **(4)**. Connect the air hose coming from the lubricator to the short hose of the MAX. Screw with nut firmly together until resistance is felt.

#### 8.4 Functions of the Lubricator

The lubricator ensures that the necessary amount of lubricant is mixed with air and supplied to MAX. The compressed air from the compressor blows through the lubricator where it mixes with the lubricant - this results in a spray effect of oil and air. In this form, it passes through the air hose to the inside of the MAX device and ensures optimum lubrication for all

moving parts. As a lubricant, we recommend EcoMAX Oil, which is safe to use and biodegradable.

A valve which is used to change the direction of the machine is located on the lubricator, by turning this handle an operator of the MAX can change a moving direction of the machine from forward to backward (reverse) and vice versa.

The lubricator (Figure 8.4.1.) comes with:

- A valve **(2)** to adjust the air supply. The valve with lever in transverse position closes the supply of compressed air. Lever in the longitudinal position means full opening of the valve
- Steering valve **(1)**. The possible positions of the control valve lever and the corresponding moving directions of the MAX (forward-backward) are shown on the Figure 8.4.1
- Oil adjustment knob **(3)** to adjust the amount of oil with the air. (min-max)
- Oil level indicator **(4)**
- Oil filler cap **(5)**



***The oil filler cap (5) should never be unscrewed whilst the MAX is in operation!***

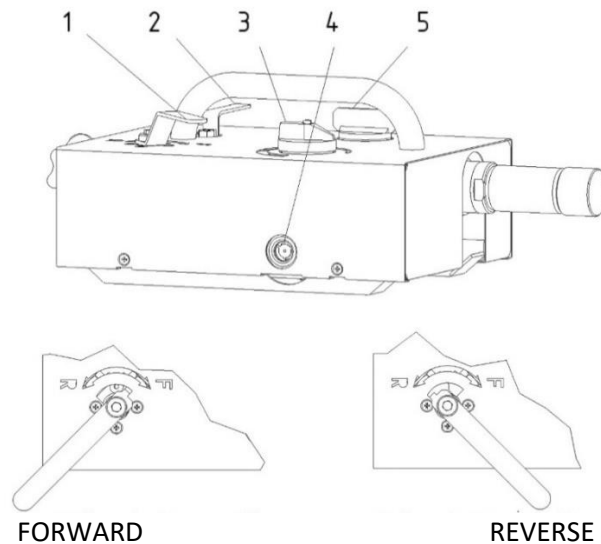

Figure 8.4.1

### 8.5 Alignment of the MAX K95S

For accurate aiming of the MAX in the starting pit, we recommend using the Optical Level Set.

To aim the machine precisely follow these steps:

- a) Position a surveying stake in the End pit in the place where the end of the borehole should be located.
- b) Place the MAX machine into the Start pit and pre-align it to the End pit, then place the TERMA telescopic sight onto the machine.
- c) With a help of TERMA telescopic sight you have to align the MAX machine to the surveying stake by changing horizontal and vertical position of the machine.

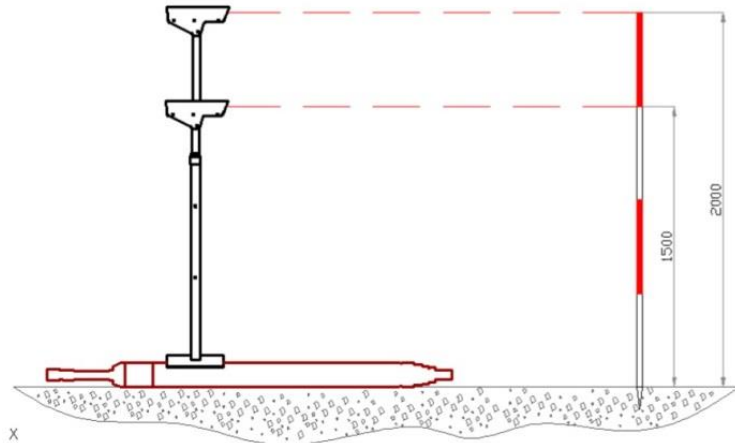

## 8.6 Solo-Boring

For this action the machine should be equipped with the End cone (Figure 5.1.1.)



***Before starting the machine it must be inspected and checked especially air hose – machine connections and fittings. Check pneumatic steering before using the device. This is especially important if it has not been in use for a long time***

To perform a Solo-Boring the next procedures should be followed:

- a) Connect the Air hose
- b) Position MAX into the starting pit and align precisely to the planned target
- c) Move the direction handle in Forward position (F).
- d) Abruptly open the air supply valve at the lubricator with a quick movement to the maximum position, to start-up the MAX.



***Ear protection should be worn when performing Solo-Boring at all times.***



***It is prohibited for anyone to stay in between the MAX and the pit wall in front of the MAX. There is a danger of Entrapment!***

- e) When the MAX starts to operate, the air supply has to be reduced. It is necessary because the MAX has not plunged into the soil yet. In case of the full air supply valve opening at the lubricator (2), the MAX will begin moving reciprocally without any forward movement. Slowly opening of the valve ensures that the MAX will slowly navigate its way into the soil while remaining stable i.e. not moving from forward to backward.
- f) As long as the MAX has not fully plunged into the soil, its moving direction should be checked for accuracy, to avoid the MAX going out of line.
- g) After the MAX has drilled into the soil for 1/2 up to 2/3 of its length (this depends on ground conditions), the air valve could be gradually opened completely.
- h) At a moment when the MAX will pass out of sight into the pit's wall, soil and debris could be exhausted from the bore and may lead to eye damage.



***During operation of the MAX, soil and other debris in combination with the exhausted air could be thrown from the back of the MAX. Stay in a safe place and use Eye protection!***

- i) During drilling, continuously monitor the air hose movement and the noises emitted from the MAX. If the hose begins to shake rapidly (reciprocatively move) in the starting pit, probably the MAX has lost its grip with borehole due to loose soil. Reduce gradually the air supply to the mole allow forward progress to continue.
- j) A good lubrication is required at every moment of machine's work. To achieve needed level of lubrication an oil adjustment knob should be set in appropriate position.
- k) When mole enters the End pit, reduce the air flow.

### 8.7 Reversing MAX K95S



***When the MAX encounters a rock or insurmountable obstacle, or an obstacle that may possibly damage the machine or change its path, MAX can be easily reversed to the starting pit in order to re-start a new borehole.***

MAX can easily reverse (move backward) to the starting pit if there is not enough space to lift the MAX out of the End pit.

MAX can easily be reversed (move backward) to the starting pit if there is not enough space to lift the MAX out of the End pit.

To reverse MAX, we should:

- a) Change the position of the steering handle on the lubricator to reverse (R). Reversing of the MAX could be done without disconnecting the air supply. (do not close the air supply valve).
- b) An operator has to ensure the tension of the air hose while reversing the machine to avoid the hose been blocked and jammed in the borehole.



***Do not attempt to reverse the mole when the tool for inserting PE/PVC pipes is attached and there is no pipe inside***



***Do not attempt to working at reverse the mole with air supply valve at maximum position. The air supply valve during the reversing has to be adjusted maximum at ¾ opened.***



***When reversing the MAX, soil and other debris in combination with the exhausted air could be thrown from the back of the MAX. Stay in a safe place and use Eye protection!***

### 8.8 Manual pulling of plastic pipes

For installing PE, PVC pipes (manually) the Insert nipple (1) could be used (Figure 8.8.1.). This method can be used for pipes of diameter  $\varnothing 25 \div \varnothing 55$  mm.

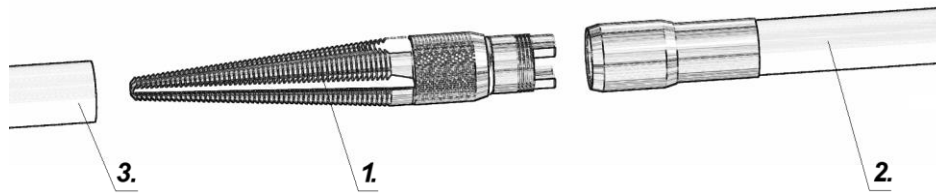

Figure 8.8.1

To insert pipes manually proceed to the following steps:

- When the MAX has completely cleared the borehole, disconnect the Air Hose from the machine (2) than disconnect the Air Hose from the Lubricator (The air hose stays in the borehole)
- Screw and tight the Insert nipple (1) into the plastic pipe (3).
- Attach the Insert nipple (1) to the Air hose (2)
- Beginning from the Starting pit pull the air hose carefully through the bore hole.

### 8.9 Direct pulling PE-, PVC- Pipes of diameter 75 mm

This method is used for the installation of a one piece plastic pipes (Figure 8.9.1).

The MAX K95S should be equipped with the Tool for pulling PE/PVC (1). Additionally a chain tool (2) is needed for screwing PE/PVC pipes into the tool.

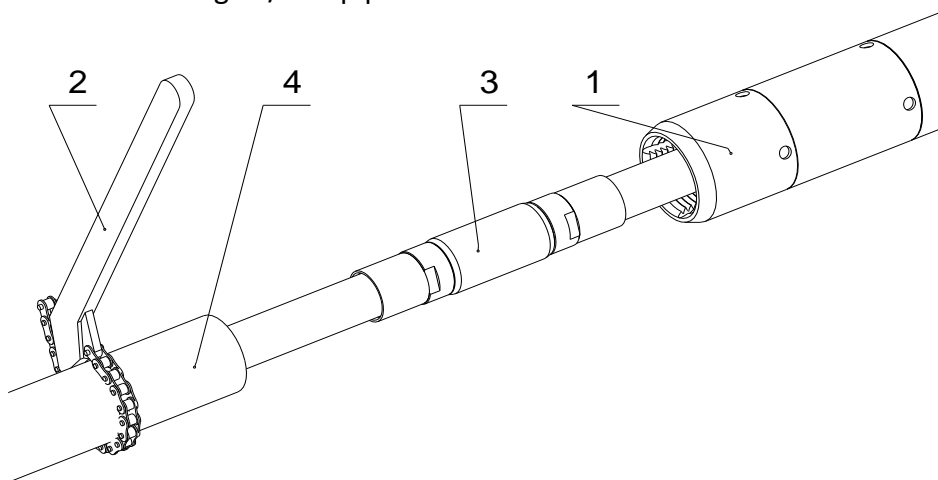

Figure 8.9.1

For the direct pulling of PE, PVC pipes please proceed as follows:

- Follow the procedure steps a) to f) just as Solo-Bore.
- MAX should be stopped when it is for  $\frac{3}{4}$  of the length into the soil
- Disconnect the air hose (3) from the small connection hose at the MAX
- Air hose (3) to be placed in the pipe (4) insert
- Connect the air hose (3) with the small connection hose at the MAX
- Screwing pipe into the screw nipple (1) using the chain tool (2)
- Start the MAX machine. During operation the consumed air will be discharged through the end part of the pipe. The soil or debris acquired during the process of connecting the pipe to the MAX can suddenly be thrown out of the pipe.



***During pipe installing there is always the possibility that soil and other debris in combination with the exhausted air could be thrown from the end of the pipes. Stay in a safe place and use Eye protection!***

- h) After the MAX has arrived in the End pit, the air supply needs to be reduced.
- i) In the End pit, enough space should be available in order to disconnect the pipes and the Air hose.
- j) Slowly close the air supply and allow the MAX to stop.
- k) Disconnect all parts, clamps and clamping plate.

### **8.10 Direct installing PE-, PVC- Pipes of diameter 90 mm**

This method is used for the installation of plastic pipes in one (Figure 8.10.1). The MAX should be equipped with the **(1)** Pipe Tool for inserting PE/PVC pipe and by pulling rope **(10)** and the clamping plate with tensioner **(7)**.

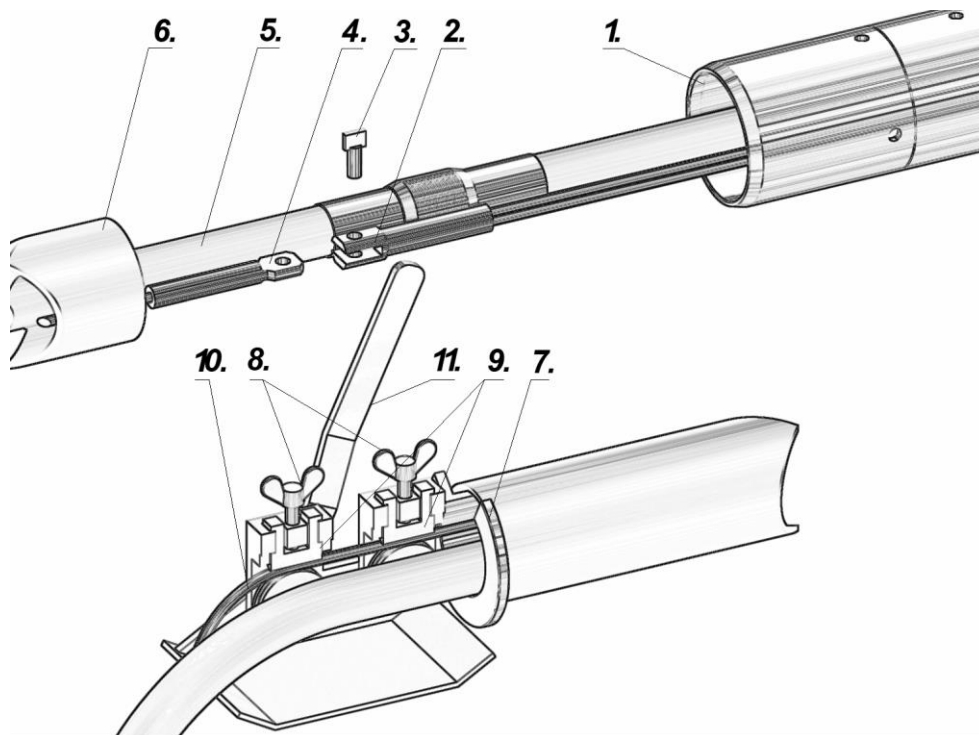

Figure 8.10.1

For the immediate retraction of PE, PVC pipes please proceed as follows:

- a) Follow the procedures as with Solo Bore, repeat step a to f.
- b) MAX needs to stop when it is for  $\frac{3}{4}$  of the length into the soil
- c) Disconnect the air hose **(5)** from the small connection hose at the MAX
- d) Air hose and pulling rope **(10)** to be placed in the pipe **(6)** insert
- e) Then forward the tied hose after pulling the rope, separate from each other again.

- f) Extensions of the connection cable **(2)** and the pulling rope **(4)** have to be link up with the screw **(3)**.
- g) The recovered pipe **(6)** in the sleeve **(1)** can now be squeezed in.
- h) Into one of the pipe ends the inserted part can be lead with the insertion piece **(7)**
- i) After the pulling rope **(10)** put the clamps **(9)** on the tensioner.
- j) The jaws of the tensioner with the screws need to be pressed down, using screws **(8)**.
- k) With the handle **(11)** pull the whole rope-tensioner-sleeve construction to the machine.
- l) After reaching a sufficient pressure on the coupled parts we can Start the mole. During operation the consumed air will be discharged through the end part of the pipe. The soil or debris acquired during the process of connecting the pipe to the MAX can suddenly be thrown out of the pipe.



***During pipe installing there is always the possibility that soil and other debris in combination with the exhausted air could be thrown from the end of the pipes. Stay in a safe place and use Eye protection!***

- m) After the mole has arrived in the End pit, the air supply needs to be reduced.
- n) In the End pit, enough space should be available in order to disconnect the pipes and the Air hose.
- o) Slowly close the air supply and allow the MAX to stop.
- p) Disconnect all parts, pulling rope, clamps and Tensioner.

### 8.11 Steel pipes ramming

For steel pipe ramming the MAX could be equipped with the tool for inserting PE/PVC pipes or with the End nut. Depending on the pipe's diameter the appropriate cone and straps should be used.

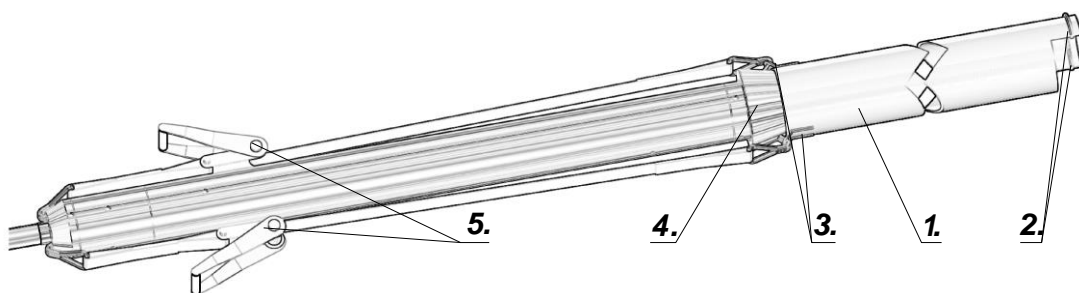

Figure 8.11.1

To ram a steel pipe the following steps should be proceeded (Figure 8.11.1.):

- a) Prepare the rammed pipe **(1)** by welding two unloading rings **(2)** at its beginning (the end that enters soil) – the first one - from the outside to reduce the pipe jamming effect in the ground during ramming and the second one - from the inside to consolidate the debris material to make it easier to remove later. At the other end weld ears **(3)** which will be used to tighten the machine with the tube by straps.
- b) Place the steel pipe in the starting pit, aligning it in the direction of the planned installation.

- c) Put the cone **(4)** into the steel pipe.
- d) Prepare a ground level under the impact mole so that the machine axis is coincide the axis of the rammed pipe.
- e) Insert the MAX's head into the cone/cones and fasten it with straps **(5)** to the pipe and to the end of the machine. The straps on one side hold the welded ears on the pipe and on the other side hold the sleeve/end cone of the MAX (see Figure 8.11.1).
- f) Compressed air hose should be connected according to 8.3.
- g) Put the lever of the lubricator in a FORWARD (F) position
- h) Start the machine



***It is prohibited for anyone to stay in between the MAX and the pit wall in front of the MAX. There is a danger of entrapment!***



***Operating crew should always wear the appropriate safety equipment: ear protection, safety shoes/boots, hard hat, safety glasses, gloves etc.***



***During pipe jacking operation the MAX K95S should not be reversed to return. This would result loose of the connection and could result damaging the cone, tube or straps.***



***During a long-lasting pipe jacking operation the cone, head, pipe and other parts of the machine can get hot, Risk of Burns!***

- i) Stop the machine after the rammed pipe would reach the end pit.
- j) Remove the straps.
- k) Put the lever of the lubricator in a REVERSE (R) position.
- l) Start the MAX to release the machine from the cone/cones.
- m) Remove the cone/cones from the steel pipe.

### **8.12 Cleaning of steel pipes after ramming**

To remove debris from the rammed pipe, prepare as follows: pipe plug **(1)** of diameter corresponding to the rammed pipe diameter, foam pipeline pig **(2)**, locking rods **(3)** to secure the pipe plug, Air hose **(4)** with valves (5, 6) (Figure 9.11.1), and a welding machine.



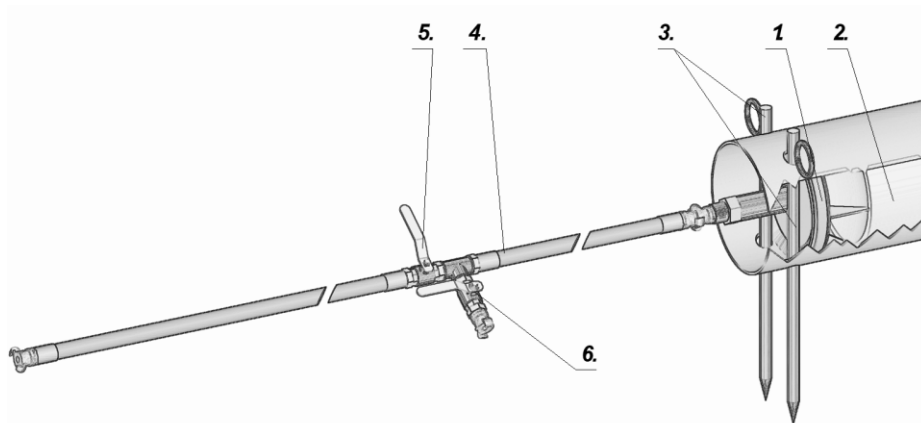

Figure 8.12.1

To remove soil and debris from a rammed pipe, follow these steps:

- a) clean the inside of the pipe from the ground to a depth of approximately  $3\div 4 \times D$  (D - pipe's diameter).
- b) make four through holes in the pipe for the locking rods **(3)** according to the figure 9.11.2.



Figure 9.11.2

- c) Wait for the pipe to cool and remove the slag from the weld to prevent damage to the pipe plug.
- d) Insert the foam pipeline pig (2) into the prepared pipe.
- e) Put the pipe plug (1) inside the pipe and secure it with the locking rods (3).
- f) Tighten the pipe plug seal with a wrench (60 mm).
- g) Connect the short end of the air hose with valves (4) to the pipe plug.
- h) Connect the other end of the air hose to the compressor.
- i) Make sure that the valves (5) and (6) on the air hose are closed and all connections are well secured and tightened.
- j) Start the compressor.
- k) Open the valve on the compressor (keep the valves on the hose closed) and wait for the hose to fill with compressed air.
- l) To start cleaning the pipe, open the valve (5) on the air hose.



***During operation of Pipe Ramming, soil and other debris in combination with the exhausted air could be thrown from the back of the machine. This can lead to serious injuries or endanger life. Stay in a safe place,***



**Never stand in line with the machine or with the pipes and always use Eye protection!**



**The area where work is carried should be marked and locked to avoid unauthorized entry to the site!**

- m) If the removing does not start after 2 minutes the compressor needs to be switched off.
- n) The operator should slowly release air pressure by gently opening the valve (6).
- o) Remove the pipe plug and the foam pipeline pig.
- p) Reinstall the pipe plug without the pipeline pig, pour some water into the air hose (4) through the valve (6), and start the compressor.
- q) Water under pressure penetrates into the voids of the soft clay soil and makes it more flexible, in addition, it reduces the friction between the inner surface of the pipe and the clay. The volume of water required depends on the actual situation. Usually it is no more than 100 liters.
- r) Disconnect compressor and relieve air pressure again. Remove the pipe plug, reinstall the foam pipeline pig and pipe plug and start the removal process from the beginning. When the removal process begins, reduce the compressed air supply to limit the ejection rate.

### 8.13 Expanding the borehole

To expand the borehole MAX K95S **(1)** should be equipped with expander/calibrator **(2)**. (Figure 8.13.1)

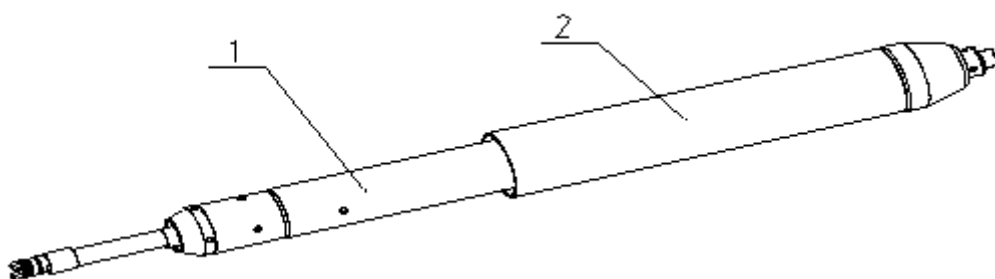

Figure 8.13.1

In order to perform expanded borehole:

- a) make a solo-bore with your impact mole (see p. 8.6. Solo boring of actual operators instruction). Please, remember that the minimum depth specification for operation of the MAX with expander is ten times the expander's diameter (10 x 127 mm = 1270 mm).
- b) Once the machine will reach the end pit it should be retracted to the start pit using the reverse function (Figure 8.4.1). It is possible to move the machine manually from the end pit to the start pit.

- c) In the starting pit introduce the mole into the expander previously installed in the bore. To do this, manually insert the mole's head into the expander and then start the mole in forward direction (Figure 8.4.1.) with minimum opening of air supply valve. (Figure 9.1.1.)

#### **ATTENTION!**

**Before installing the mole into the expander, carefully clean all the dirty surfaces of the mole's cylinder (Figure 5.1.1) and check and clean the inner surface of the expander. Any dirt left on them will quickly lead to wear of the guide elements in the expander.**

- d) Then the bore expanding process could be performed.

#### **8.14 After care**

- Each time that the hose is disconnected, the security cap should be placed, to avoid any debris entering the hoses. Do the same when disconnecting the connectors on the MAX. It is especially important to place the security cap on the short connecting hose for the MAX, as debris inside this hose cannot be blown out by air. If any dirt from the hose gets inside the MAX, damaged parts or a damaged MAX can result.



***Before disconnecting Air hoses, make sure the air supply has been switched off.***

- When lifting or carrying the MAX, follow the instructions in section 6. Transport
- After the MAX has finished the boring in the Start or End pit, it is recommended to remove any soil or debris from the MAX. To carry out this procedure the air hose needs to be connected and the MAX needs to be turned on for 30 seconds.
- It is important that MAX and accessories are kept clean to ensure their proper functioning.
- The Air hose needs to be cleaned and rolled up - avoid nicking the hose.

## **9 Maintenance**



***It is prohibited to repair, perform internal inspections or carry out any maintenance on MAX. Maintenance only can be performed by a qualified technician who has been trained to perform these jobs, or, alternatively at a manufacturer service center.***

***Technical changes to MAX, repairs and maintenance carried out, outside of a manufacturers service center, will invalidate MAX's warranty and guarantee claims.***



***It is prohibited to use MAX or its accessories when they are in sub-standard, technically poor condition.***

### **9.1 Routine maintenance**

The daily inspection should include:

- a) External visual inspection of the machine, lubricator and hoses.

- b) Check the screw connections of the head, cylinder, tail piece and make sure there is no gap between elements.
- c) Check the connections and fittings of the hoses as well as on the lubricator.
- d) Check the air hoses for damages.
- e) Check the condition of the seals of the pneumatic hoses
- f) Control the oil level in the lubricator.
- g) Check for any oil leaks in the lubricator and its valves.

Maintenance after completion of work includes :

**a) Normal dry working conditions**

- place the machine on a dry surface.
- turn the machine on for 20 seconds with maximum lubrication (Figure 9.1.1)

**b) Wet working conditions (wet ground, rain, snow)**

- place the machine on a dry surface.
- turn the machine on for 30 seconds with minimum lubrication (Figure 9.1.1)
- pour 150ml of anti-corrosion oil **KorMAX** into the short hose (both inner and outer hoses) connected to the machine.

turn on the machine for 3-5 seconds to distribute the oil through the inside of the machine.

**c) Penetration of the machine with debris (mud, clay, sand etc.)**

- place the machine on a dry surface.
- pour 200ml diesel fuel into the short hose (both inner and outer hoses) connected to the machine.
- turn on the machine for 30 seconds to distribute the oil through the inside of the machine and gradually dissolve all contaminants, then turn off the machine.
- pour 150ml anti-corrosion oil **KorMAX** into the short hose (both inner and outer hoses) connected to the machine.
- turn on the machine for 3-5 seconds to distribute the oil through the inside of the machine.

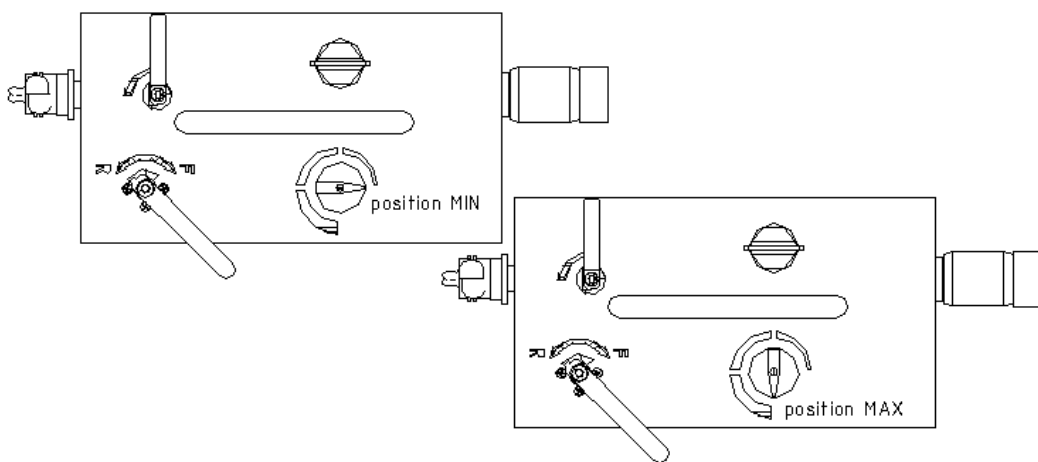

Figure 9.1.1

**9.2 In case MAX has not been in use for a while**

If the machine will not be used for more than 7 days, it should be properly preserved. This is best to be done in our workshop or in one of the workshops of our authorized dealers. If you do not have this possibility, you can do the following:

- a) By compressed air clean the hose from sand, oil and water with the lubricating valve in closed position.
- b) Connect and start the machine with the lubricating valve in closed position..
- c) During these operations you need to change the direction valve several times R>F .
- d) The action described In point c, should be repeated until no more water and oil comes from the machine.
- e) Stop the machine and disconnect the air hose and add 150 cm<sup>3</sup> of anti-corrosion oil **KorMAX** in the small air hose connected to the machine (in the inside as well as in the outside hose).



***Before decoupling the air hose, check that it is not under pressure!***

- e) Connect the hoses and restart the machine.
- f) During these operations you need to change the direction valve several times R>F .
- g) Stop the machine, disconnect the hoses and place caps on the machine and hoses.

### 9.3 Technical inspections

Inspections should only be done by qualified and trained personnel, in accordance to the schedule below:

- |                 |  |
|-----------------|--|
| I Inspection:   | before the end of the 6th Month by standard operation  |
| II Inspection:  | before the end of the 12th Month by standard operation |
| III Inspection: | before the end of the 18th Month by standard operation |

Inspection of MAX includes:

- a) Disassemble all parts of MAX
- b) Clean all parts
- c) Inspect all components, checking for wear and tear:
  - Piston
  - Front and backside of the piston, for air leaks
  - Control connection
  - Cylinder slide
  - Pistons seal and rings
  - Injection hose sleeves
  - all connections in reverse mechanism

Inspection of the Air hose:

- a) Check pressed sleeves.
- b) Check all couplings for wear and tear, possibly, renew the seals.

Inspection of the lubricator:

- a) Check the valves for leaks and smooth operation.
- b) Check the couplings for wear and possibly replace seals.
- c) Check the needle and all around it, possibly replace seals and adjustment.
- d) Check the pipes for blockages and clean or replace them if necessary.

## 10 Troubleshooting

Faults	Reason	Solution
Starting problems	Air supply valve at the lubricator is opened too slowly	Air intake valve to the lubricator needs to be opened quickly
	Piston is located in the center position	Change the control valve on the lubricator quickly from F to R to F
	Low pressure of the incoming air	Adjust the compressor to 7 atm.
	Damage to the seals of the Piston	Replace the seals
	Air flow is reduced -the hose is nicked or is not fully laid out	Clean pneumatic hoses
	Insufficient lubrication	Put Some oil (50 ml) into the air hose
The performance of MAX is less than usual	Low air pressure	Adjust the compressor to 7 atm.
	Damage to the seals of the Piston or Controller	Replace the seals
	Insufficient lubrication	Increase oil flow by turning the handle on the lubricator. To achieve immediate results, you can pour oil directly into the compressed air hose
	Piston clamping due to dirt on the seals.	Assemble MAX and clean all seals
	Piston clamping due to impact on the piston seal rings. Piston-cylinder friction	Replace percussion piston seal rings. Investigate the cylinder slide. Polish visible parts.
	Pressure loss through leaking couplings or hose	Replace seals and or/hose
MAX cannot change direction	Piston is clamping due to dirt on control parts	Remove control parts, clean and replace.
	Defective seals in controller	Replace seals
	Defective control hose (seals inside the air hose)	Replace seals in the control hose
MAX moves forward and backward whilst entering the pit wall.	MAX does not have enough resistance from the soil (friction). Lack of resistance may occur in Wet ground	Reduce the air supply by the valve at MAX lubricator.
MAX works very slowly	There is not enough pressure from the compressor to increase the MAX's functioning speed.	Check the air pressure coming from the compressor and adjust to 7 bar
	Air escapes through damaged seals or leaks in hoses	Replace seals on/or hoses
Machine change the trajectory	Alignment was incorrect	Adjust the position with the use of the optical instruments
	MAX defers from its set direction due to wet ground conditions	Reduce the air supply through the valve on the lubricator
	The head is worn	Replace the head



**TERMA**  
SINCE 1990

<http://www.termagroup.pl>

e-mail: [mole@termamax.com](mailto:mole@termamax.com)

<http://termamoling.pl>

**MAX** *Impact Power*

Your Local Dealer:

.....  
.....  
.....  
.....  
.....  
.....

# 11. Spare parts

## 11.1 MAX K95S – mole spare parts list

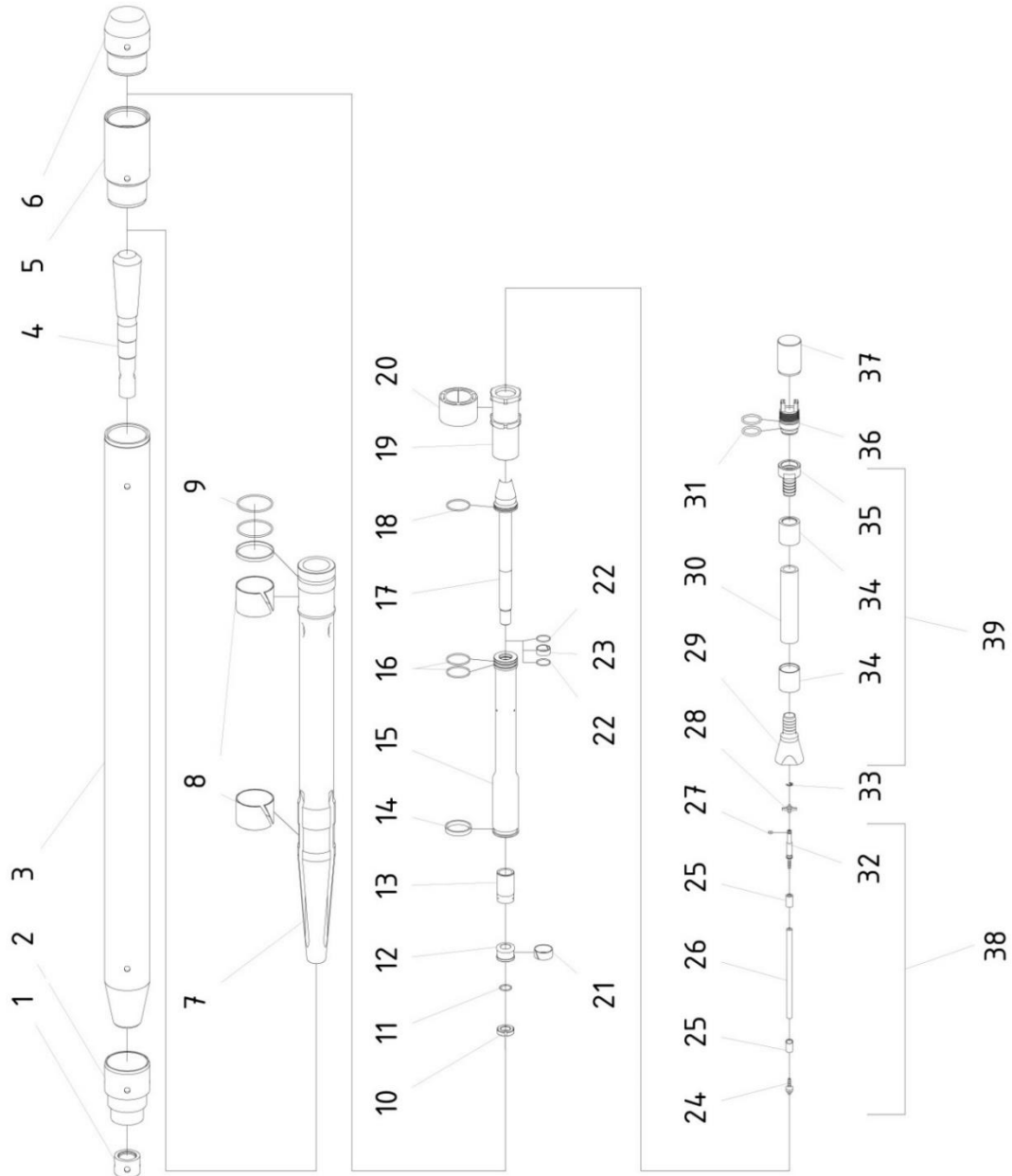



No.	Name	Item number	QTY
1.	Stepped head nut	PMNAK-M095-00.09	1
2.	Stepped head	PMNAS-M095-00.01-M3	1
3.	Cylinder	PMCYL-M095-00.02-M2	1
4.	Chisel	PMPRZ-M095-00.08	1
5.	Control stud housing	PMTSR-M095-00.03	1
6.	Reverse cone with pulling eyes	WAHW095	1
7.	Impact piston	PMBIJ-M095-00.05-M3	1
8.	Piston teflon sliding tapes	PMPRB-M095-00.06	2
9.1.	Piston seal (Teflon)	PMUSB-M095-00.07	1
9.2.	Piston seal (O-ring 69x3)	MTSORSI0033	2
10.	Control rod nut	PMNKSP-S095-00.10	1
11.	Seal (O-ring 22x2)	MTSORSI0011	1
12.	Inner piston	PMTLOK-S095-00.04	1
13.	Elastic damper	PMAMOR-S095-00.06	1
14.	Control piston teflon seal	PMUTS-S095-00.01-P3	1
15.	Control piston	PMTLS-S095-00.02	1
16.	Control piston seal II (2x O-ring 45x2,5)	MTSORSI0016	2
17.	Control rod	PMRUS-S095-00.05	1
18.	Control cylinder seal (O-ring 45x2,5)	MTSORSI0016	1
19.	Control cylinder	PMCYLSTR-S095-01.00	1
20.	Elastic block	PMLST-S095-00.08	1
21.	Inner piston sliding tape I	PMPT1-S095-00.03	1
22.	Control piston seal III (2x O-ring 26x2)	MTSORSI0012	2
23.	Control rod sliding tape II	PMPT2-S095-00.09	1
24.	Control hose connector	PMKWC-S095-00.11	1
25.	Control hose crimping ferrule M95	PMTULZW-W095-00.11	2
26.	Control whip hose 0,20 m	MTSWG0016	m
27.	Control hose seal (O-ring 4.3x2.4)	MTSORNB0004	1
28.	Control hose cross spacer M95	PMWWC-W095-00.08	1
29.	Outer hose barbed connector	PMKWG-S095-00.07	1
30.	Outer whip hose (0,15 m)	MTSWG0018	m
31.1.	Coupler seal (O-ring 32x4)	MTSORIU0005	1
31.2.	Coupler seal (O-ring 35x3,5)	MTSORIU0006	1
32.	Control hose barbed coupling (male)	PMLWCM-W095-00.07	1
33.	Retaining ring (E-clip) M95	MMEMNPZ0004	1
34.	Outer hose crimping ferrule M95	PMTULZW-W095-00.10	2
35.	Outer hose barbed coupling female M95	PMLWG-W095-00.04	1
36.	Outer hose quick coupler (male) M95	PMSRB-W095-00.05	1
37.	Dirt cap (female)	PMZAZ-W095-00.06	1
38.	Control whip hose, complete (Pos. 24, 25 x 2, 26 x 0.20, 32, 27)	PMWKC095K	1
39.	Outer whip hose, complete (Pos. 29, 30 x 0.15, 34 x 2, 35, shrink, work)	WAWZ095	1
...	Shrink pipe RPK 40/12 for whip hoses M65, M75, M95	TMRPK40/012	1
...	Seal kit M95 basic (Pos. 8 x 2, 9, 14, 27)	WAUM095M	1
...	Seal kit M95 complete (Pos. 8 x 2, 9, 11, 14, 16 x 2, 18, 21, 22 x 2, 23, 27, 31)	WAUK095	1

## 11.2 Pneumatic Air hose 20 m spare parts list

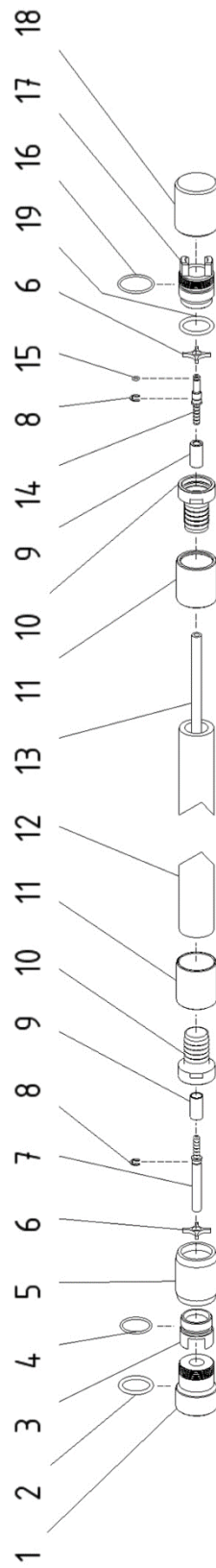

No.	Name	Item number	QTY
1.	Dirt plug (male)	PMZAW-W095-00.01	1
2.	Dirt plug seal (O-Ring 32x4)	MTSORIU0005	1
3.	Outer hose quick coupler (female)	PMLWZ-W095-00.03	1
4.	Coupler seal (O-Ring 29x3,5)	MTSORNB0030	1
5.	Coupler nut	PMNAW-W095-00.02	1
6.	Control hose cross spacer M95	PMWWC-W095-00.08	2
7.	Control hose barbed coupling (female)	PMLWCZ-W095-00.09	1
8.	Retaining ring (E-clip) M95	MMEMNPZ0004	2
9.	Control hose crimping ferrule M95	PMTULZW-W095-00.11	2
10.	Outer hose barbed coupling female M95	PMLWG-W095-00.04	2
11.	Outer hose crimping ferrule M95	PMTULZW-W095-00.10	2
12.	Outer hose 20 m	MTSWG0010	m
13.	Control hose 20 m	MTSWG0016	m
14.	Control hose barbed coupling (male)	PMLWCM-W095-00.07	1
15.	Control hose seal (O-Ring 4,3x2,4)	MTSORNB0004	1
16.	Coupler seal (O-ring 35x3,5)	MTSORIU0006	1
17.	Outer hose quick coupler (male) M95	PMSRB-W095-00.05	1
18.	Dirt cap (female)	PMZAZ-W095-00.06	1
19.	Coupler seal (O-ring 32x4)	MTSORIU0005	1
...	Control hose 20m, complete M95 (Pos. 7, 9 x 2, 13 x 20, 14, 15, work)	WAWWC095W	1
...	Air supply/control hose 20 m, complete M95	WAWZ09520	1

### 11.3 Lubricator with reversing mechanism

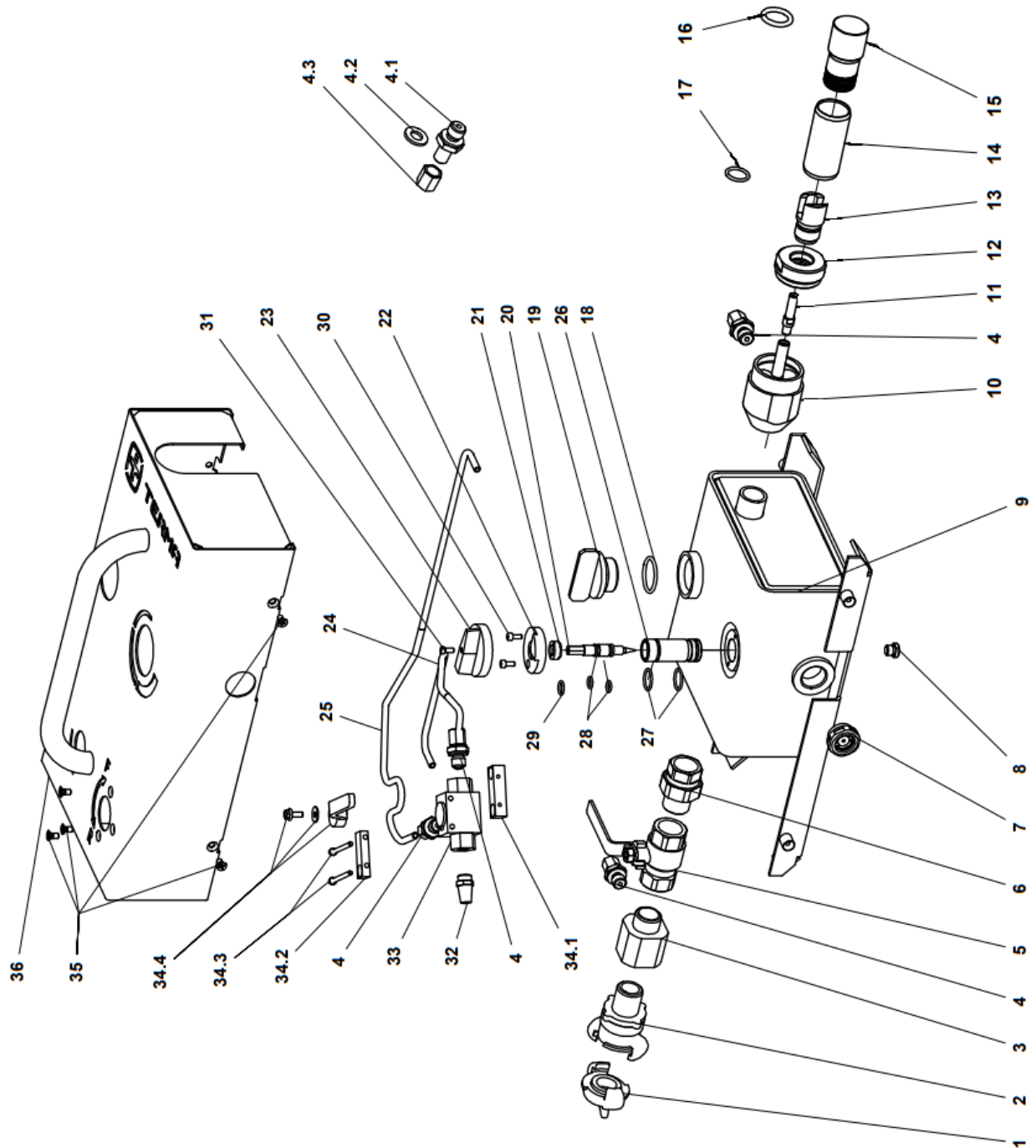

Nr.	Name	Item number	QTY
1	GEKA dust cap with chain 42 mm	MMEHYZS0002	1
2	GEKA GZ-Coupling 42 mm 3/4"	MMEHYZL0002	1
3	Splitter II	PMRZG2-OL130-00.01	1
4.1.	XGE 6LR fitting from 1/4" straight connector	MMEHYZL0006	4
4.2.	DPR 6L/S compression ring from 1/4" straight connector	MMEMNIN0004	4
4.3.	Nut M12x1.5 M 6L from the straight connector 1/4"	MMEMNNA0006	4
5	Ball valve 3/4"	MMEHYZA0004	1
6	Threaded plug GN 749 1/8"	MMEMNKR0002	1
7	Union fitting 3/4"	MMEHYSR0001	1
8	Oil level sight glass 3/4"	MMEMNIN0008	1
9	Tank container	PMZZM-OL130-01.00-M1	1
10	Splitter I (set)	PMRZG1-OL130-03.00-M1	1
11	Straight standpipe hose tail 55	PMKWO-OL095-00.02	1
12	Reducer M55	PMRD-OL095-00.03	1
13	Outer hose connector (female) M55	PMLWZ-W095-00.03	1
14	Air hose nut M55	PMNAW-W095-00.02	1
15	End cap M55 (male)	PMZAW-W095-00.01	1
16	O-ring 21x4 80NBR	MTSORIU0005	1
17	O-ring 17,3x2,4 NBR70	MTSORSI0013	1
18	O-ring 30,2x3 of oil cap, 70NBR	MTSORNB0032	1
19	Oil cap	PMKWO-OL130-04.00	1
20	Needle valve	PMIGL-OL130-02.00	1
21	Gland (stuffing box)	PMDŁ-OL130-02.03	1
22	Clamping plate	PMJAR-OL130-00.04-M2	1
23	Flow control knob	PMPOL-OL130-00.05-M2	1
24	Hydraulic pipe fi6x1	MMERUHY0001	0,39
25	Hydraulic pipe fi6x1	MMERUHY0001	0,57
26	Needle seat	PMGNIG-OL130-02.01	1
27	Needle seal (O-ring 18x2)	MTSORNB0011	2
28	Needle seal (O-ring 8x2)	MTSORNB0056	2
29	Gland seal (O-ring 10x2)	MTSORNB0001	1
30	Clamping plate screw M4x10 DIN 912	MMEMNSR0058	2
31	Flow control knob screw M4x10 DIN 933	MMEMNSR0059	1
32	Sintered bronze silencer 2931-1/4" Camozzi	MMEHYTL0001	1
33	Three way ball valve with holes 1/4" BSP 500 BAR	MMEHYZAOTW0005	1
34.1	Valve mounting block 1	PMKMZ-OL130-07.01	1
34.2	Valve mounting block 2	PMKMZ-OL130-07.02	1
34.3	Allen screw M4x50 ISO4762 OC 5,8	MMEMNSR0658	2
34.4	Handle for three-way ball valve 1/4" WKH and WKH3 (R12)	MMEHYZA00065	1
35	Screw M5x10 Z (WSM)	MMEMNWK0026	7
36	Oiler body	PMOOM-OL130-05.00Z	1